

- Hot Plug Protection
- Quad 1.0 to 2.5 Gigabits Per Second (Gbps) Serializer/Deserializer
- Independent Channel Operation
- 2.5-V Power Supply for Low Power Operation
- Selectable Signal Preemphasis for Serial Output
- Interfaces to Backplane, Copper Cables, or Optical Converters
- Lock Indication and Sync Mode for Fast Initialization
- 18-Bit Parallel Buses for Flexible Interface Applications
- On-Chip PLL Provides Clock Synthesis From Low-Speed Reference
- Receiver Differential Input Thresholds 200 mV Min
- Rated for Industrial Temperature Range
- Typical Power: 1700 mW at 2.5 Gbps
- Ideal for High-Speed Backplane Interconnect and Point-to-Point Data Link
- Internal Passive Receive Equalization
- Small Footprint 19 mm x 19 mm, 289-Ball PBGA Package

## description

The TLK4250 device is a four-channel, multi-gigabit transceiver used in high-speed bidirectional point-to-point data transmission systems. The four channels in the transceiver are configured as four separate links. The transceiver supports an effective serial interface speed of 1.0 Gbps to 2.5 Gbps per channel, providing up to 2.25 Gbps of data bandwidth per channel.

The primary application of the transceiver is to provide high-speed I/O data channels for point-to-point baseband data transmission over controlled impedance media of approximately 50  $\Omega$ . The transmission media can be a printed-circuit board, copper cables, or fiber-optic cable. The maximum rate and distance of data transfer depend on the attenuation characteristics of the media and the noise coupling to the environment.

The transceiver can also replace parallel data transmission architectures by providing a reduction in the number of traces, connector pins, and transmit/receive pins. Parallel data loaded into the transmitter is delivered to the receiver over a serial channel, which can be a coaxial copper cable, a controlled impedance backplane, or an optical link. The data is then reconstructed into its original parallel format. It offers significant power and cost savings over current solutions, as well as scalability for higher data rate in the future.

The transceiver performs the data parallel-to-serial and serial-to-parallel conversions. The clock extraction functions as a physical layer interface device. The serial transceiver interface operates at a maximum data rate of 2.5 Gbps. Each transmitter latches 18-bit parallel data at a rate based on the supplied reference clock (GTx\_CLK). The 18-bit parallel data is internally encoded into 20 bits by framing the 18-bit data with start and stop bits. The resulting 20-bit frame is then transmitted differentially at 20 times the reference clock (GTx\_CLK) rate.

The receiver section performs the serial-to-parallel conversion on the input data, synchronizing the resulting 20-bit wide parallel data to the recovered clock (Rx\_CLK). It then extracts the 18 bits of data from the 20-bit wide data resulting in 18 bits of parallel data at the receive data terminals (RDx[0:17]). This results in an effective data payload of 0.9 Gbps to 2.25 Gbps (18 bits data x GTx\_CLK frequency) per channel.

The transceiver provides an internal loopback capability for self-test purposes. Serial data from the serializer is passed directly to the deserializer, allowing the protocol device a functional self-check of the physical interface.



Please be aware that an important notice concerning availability, standard warranty, and use in critical applications of Texas Instruments semiconductor products and disclaimers thereto appears at the end of this data sheet.

PowerPAD is a trademark of Texas Instruments.

**PRODUCTION DATA** information is current as of publication date. Products conform to specifications per the terms of Texas Instruments standard warranty. Production processing does not necessarily include testing of all parameters.

# TLK4250

## QUAD 1.0 to 2.5 Gbps TRANSCEIVER

SWRS025C – APRIL 2004 – REVISED JULY 2007

---

The transceiver is designed to be hot plug capable. An on-chip power-on reset circuit holds the Rx\_CLK low during power up. This circuit also places the parallel side output signal terminals, DOUTTxP and DOUTTxN, into a high-impedance state during power up.

The transceiver uses a 2.5-V supply. The I/O section is 3-V compatible. With the 2.5-V supply, the transceiver is power efficient, consuming less than 1700 mW typically. The transceiver is characterized for operation from -40°C to 85°C.

### AVAILABLE OPTIONS

T <sub>A</sub>	PACKAGE	SYMBOL
	PLASTIC BALL GRID ARRAY (PBGA)	
-40°C to 85°C	TLK4250IGPV	
	TLK4250IZPV	ECAT

NOTE: For the most current package and ordering information, see the Package Option Addendum at the end of this document, or see the TI website at [www.ti.com](http://www.ti.com).

**TLK4250**  
**QUAD 1.0 to 2.5 Gbps TRANSCEIVER**  
 SWRS025C – APRIL 2004 – REVISED JULY 2007

	A	B	C	D	E	F	G	H	J	K	L	M	N	P	R	T	U	
17	TDB1	TDB0	DOU <sub>TT</sub> B <sub>P</sub>	DOU <sub>TT</sub> B <sub>N</sub>	PREEMP <sub>HB</sub>	DINRBP	DINRBN	RDB0	GND	TDC0	DOU <sub>TT</sub> C <sub>P</sub>	DOU <sub>TT</sub> C <sub>N</sub>	PREEMP <sub>HC</sub>	DINRCP	DINRCN	RDC0	RDC1	17
16	TDB4	TDB2	GND	GND	VDD	GND	GND	RDB1	VDD	TDC1	GND	GND	VDD	GND	GND	RDC2	RDC4	16
15	TDB5	TDB3	GND	RDB3	VDD	RDB2	GND	VDD	GND	VDD	GND	TDC2	VDD	VDD	GND	RDC3	RDC5	15
14	TDB7	TDB6	VDD	RB_CLK	RDB7	RDB4	RDB5	RDB6	GND	TDC5	TDC6	TDC7	TDC4	TDC3	GND	RDC6	RDC7	14
13	TDB8	GTB_CLK	GND	RDB17	RDB13	RDB10	RDB9	RDB8	VDD	GTC_CLK	TDC9	TDC10	TDC11	TDC14	VDD	RDC8	RC_CLK	13
12	TDB9	TDB10	VDD	SYNCB	RDB16	RDB14	RDB12	RDB11	VDD	TDC8	TDC12	TDC13	TDC16	LOOPEN <sub>C</sub>	GND	RDC10	RDC9	12
11	TDB11	TDB13	GND	VDD	LOCKBB	RDB15	GND	GND	GND	GND	GND	TDC15	VDD	TESTEN <sub>C</sub>	GND	RDC13	RDC11	11
10	TDB12	GND	TDB15	LOOPEN <sub>B</sub>	ENABLE <sub>B</sub>	TESTEN <sub>B</sub>	GND	GND	GND	GND	GND	TDC17	SYNCC	RDC17	RDC14	GND	RDC12	10
9	TDB14	TDB16	GND	TDB17	GND	VDD	GND	GND	GND	GND	GND	ENABLE <sub>C</sub>	LOCKBC	GND	RDC16	RDC15	VDD	9
8	RDA0	RDA1	VDD	RDA6	RDA8	RDA11	GND	GND	GND	GND	GND	TDD8	VDD	GTD_CLK	TDD5	TDD1	TDD0	8
7	DINRAN	GND	GND	RDA5	RDA9	RDA12	GND	GND	GND	GND	GND	TDD12	TDD9	TDD6	GND	GND	DOU <sub>TT</sub> D <sub>P</sub>	7
6	DINRAP	GND	RDA2	RDA4	RDA10	RDA14	RDA15	TESTEN <sub>A</sub>	ENABLE <sub>D</sub>	TDD17	TDD15	TDD13	TDD10	TDD7	TDD2	GND	DOU <sub>TT</sub> D <sub>N</sub>	6
5	PREEMP <sub>HA</sub>	VDD	VDD	RDA7	RDA13	RDA16	LOCKB <sub>A</sub>	ENABLE <sub>A</sub>	GND	SYNCD	VDD	TDD16	TDD11	TDD4	VDD	VDD	PREEMP <sub>HD</sub>	5
4	DOU <sub>TT</sub> A <sub>N</sub>	GND	RDA3	RA_CLK	RDA17	SYNCA	VDD	LOOPEN <sub>A</sub>	TDA17	RDD17	LOCKBD	LOOPEN <sub>D</sub>	TDD14	TDD3	VDD	GND	DINRDP	4
3	DOU <sub>TT</sub> A <sub>P</sub>	GND	GND	VDD	GND	VDD	GND	TDA15	RDD16	RDD15	GND	TESTEN <sub>D</sub>	VDD	GND	GND	GND	DINRDN	3
2	TDA0	TDA2	TDA3	TDA6	GTA_CLK	TDA10	TDA13	GND	TDA16	RDD14	RDD13	RDD10	RDD8	RDD6	RDD3	RDD2	RDD0	2
1	TDA1	TDA4	TDA5	TDA7	TDA8	TDA9	TDA11	TDA12	TDA14	RDD12	RDD11	RDD9	RD_CLK	RDD7	RDD5	RDD4	RDD1	1

# TLK4250 QUAD 1.0 to 2.5 Gbps TRANSCEIVER

SWRS025C – APRIL 2004 – REVISED JULY 2007

## functional block diagram

A detailed block diagram of each channel is shown below. Channels A, B, C, and D are identical and are configured as four separate links.

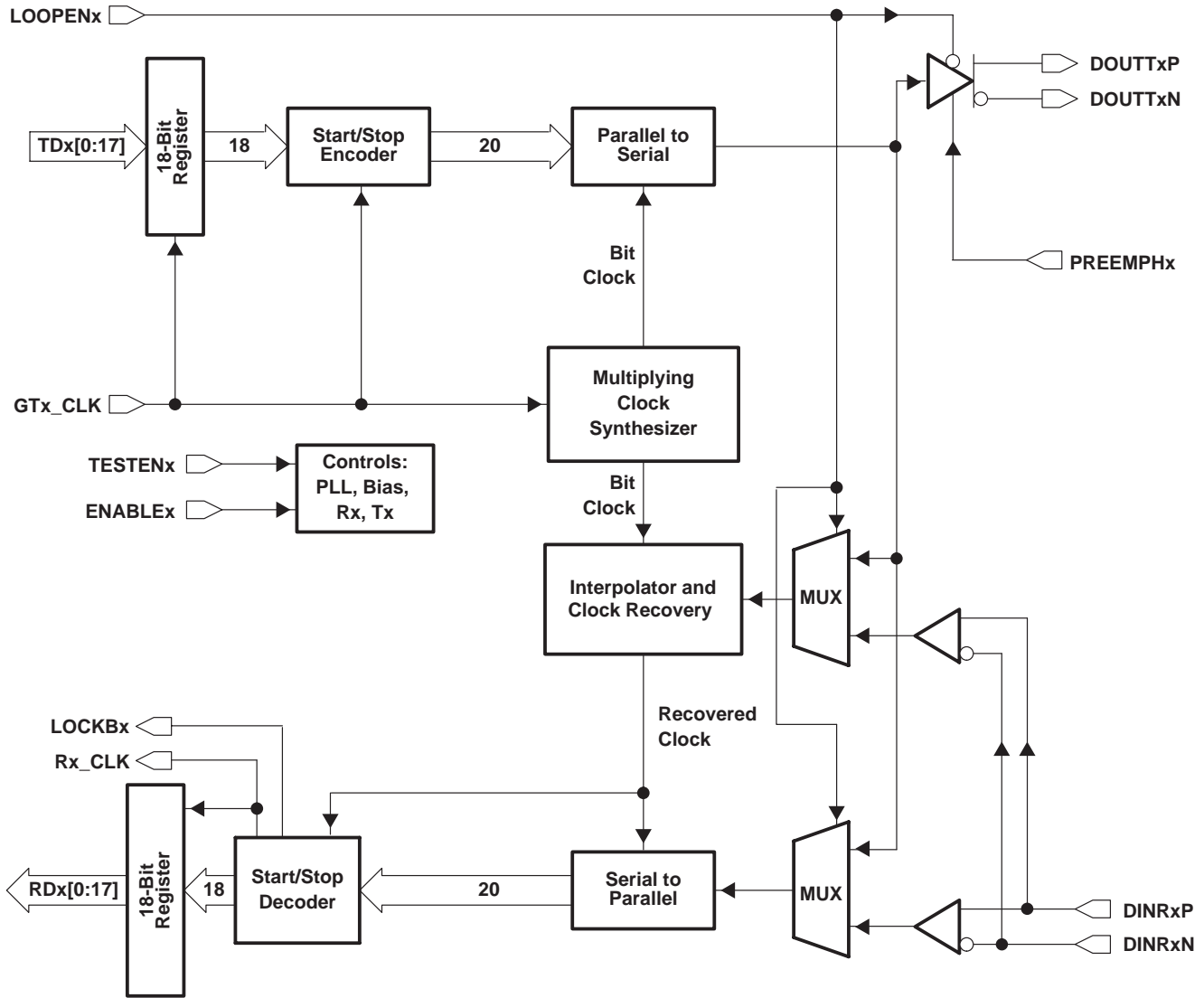

### Terminal Functions

TERMINAL		TYPE	DESCRIPTION
NAME	NO.		
DINRAP DINRAN	A6 A7	Input	Serial receive inputs. DINRxP and DINRxN together are the differential serial inputs that interface from a copper or an optical I/F module.
DINRBP DINRBN	F17 G17		
DINRCP DINRCN	P17 R17		
DINRDP DINRDN	U4 U3		
DOUTTAP DOUTTAN	A3 A4		
DOUTTBP DOUTTBN	C17 D17	Output (high-z power up)	Serial transmit outputs. DOUTTxP and DOUTTxN are differential serial outputs that interface to copper or an optical I/F module. These terminals transmit NRZ data at a rate of 20 times the GTx_CLK value. DOUTTxP and DOUTTxN are put in a high-impedance state when LOOPENx is high and are active when LOOPENx is low. During power-on reset these terminals are high impedance.
DOUTTTP DOUTTTCN	L17 M17		
DOUTTDTP DOUTTDN	U7 U6		
DOUTTDTP DOUTTDN	U7 U6		
ENABLEA ENABLEB ENABLEC ENABLED	H5 E10 M9 J6	Input (w/pullup)	Device enable. When this terminal is held low, the device is placed in power-down mode. When asserted high while the device is in power-down mode, the transceiver goes into power-on reset before beginning normal operation.
GTA_CLK GTB_CLK GTC_CLK GTD_CLK	E2 B13 K13 P8		
SYNCA SYNCB SYNCC SYNCD	F4 D12 N10 K5		
LOOPENA LOOPENB LOOPENC LOOPEND	H4 D10 P12 M4		
LOCKBA LOCKBB LOCKBC LOCKBD	G5 E11 N9 L4	Output	Receiver lock. When this signal is asserted low, it indicates that the receiver has acquired bit synchronization on the data stream and has located the start/stop bits so that the deserialized data presented on the parallel receive bus is properly received.
PREEMPHA PREEMPHB PREEMPHC PREEMPHD	A5 E17 N17 U5		

# TLK4250

## QUAD 1.0 to 2.5 Gbps TRANSCEIVER

SWRS025C – APRIL 2004 – REVISED JULY 2007

### Terminal Functions (Continued)

TERMINAL		TYPE	DESCRIPTION
NAME	NO.		
RDA[0:17]	A8, B8, C6, C4, D6, D7, D8, D5, E8, E7, E6, F8, F7, E5, F6, G6, F5, E4	Output (hi-z on power up)	Receive data bus. These outputs carry 18-bit parallel data output from the transceiver to the protocol device, synchronized to Rx_CLK. The data is valid on the rising edge of Rx_CLK as shown in Figure 7. These terminals are high-impedance during power-on reset.
RDB[0:17]	H17, H16, F15, D15, F14, G14, H14, E14, H13, G13, F13, H12, G12, E13, F12, F11, E12, D13		
RDC[0:17]	T17, U17, T16, T15, U16, U15, T14, U14, T13, U12, T12, U11, U10, T11, R10, T9, R9, P10		
RDD[0:17]	U2, U1, T2, R2, T1, R1, P2, P1, N2, M1, M2, L1, K1, L2, K2, K3, J3, K4		
RA_CLK	D4	Output (low on power up)	Recovered clock. Output clock that is synchronized to RDx. Rx_CLK is the recovered serial data rate clock divided by 20. Rx_CLK is held low during power-on reset.
RB_CLK	D14		
RC_CLK	U13		
RD_CLK	N1		
TDA[0:17]	A2, A1, B2, C2, B1, C1, D2, D1, E1, F1, F2, G1, H1, G2, J1, H3, J2, J4	Input	Transmit data bus. These inputs carry the 18-bit parallel data output from a protocol device to the transceiver for encoding, serialization, and transmission. This 18-bit parallel data is clocked into the transceiver on the rising edge of GTx_CLK as shown in Figure 6.
TDB[0:17]	B17, A17, B16, B15, A16, A15, B14, A14, A13, A12, B12, A11, A10, B11, A9, C10, B9, D9		
TDC[0:17]	K17, K16, M15, P14, N14, K14, L14, M14, K12, L13, M13, N13, L12, M12, P13, M11, N12, M10		
TDD[0:17]	U8, T8, R6, P4, P5, R8, P7, P6, M8, N7, N6, N5, M7, M6, N4, L6, M5, K6		
TESTENA	H6	Input (w/pulldown)	Test mode enable. This terminal must be left unconnected or tied low.
TESTENB	F10		
TESTENC	P11		
TESTEND	M3		
<b>POWER</b>			
VDD	C8, C12, C14, D3, D11, F3, F9, G4, H15, J12, J13, J16, K15, L5, N3, N8, N11, P15, R4, R13, U9	Supply	Digital logic power. Provides power for all digital circuitry and digital I/O buffers.
VDDAA	B5, C5	Supply	Analog power. VDDAx provides a supply reference for the high-speed receiver and transmitter analog circuits.
VDDAB	E15, E16		
VDDAC	N15, N16		
VDDAD	R5, T5		

**Terminal Functions (Continued)**

TERMINAL		TYPE	DESCRIPTION
NAME	NO.		
<b>GROUND</b>			
GNDA	B3, B4, B6, B7, C16, D16, F16, G16, L16, M16, P16, R16, T3, T4, T6, T7	Ground	Analog ground. GNDA provides a ground reference for the high-speed receiver and transmitter analog circuits.
GND	B10, C3, C7, C9, C11, C13, C15, E3, E9, G3, G7, G8, G9, G10, G11, G15, H2, H7, H8, H9, H10, H11, J5, J7, J8, J9, J10, J11, J14, J15, J17, K7, K8, K9, K10, K11, L3, L7, L8, L9, L10, L11, L15, P3, P9, R3, R7, R11, R12, R14, R15, T10	Ground	Digital logic ground. Provides a ground for the logic circuits and digital I/O buffers.

**transmit interface**

The transmitter portion registers valid incoming 18-bit-wide data (TDx[0:17]) on the rising edge of GTx\_CLK. The data is then framed with start and stop bits, serialized, and transmitted sequentially over the differential high-speed I/O channel. The clock multiplier multiplies the reference clock (GTx\_CLK) by a factor of 10, creating a bit clock. This internal bit clock is fed to the parallel-to-serial shift register, which transmits data on both the rising and falling edges of the bit clock providing a serial data rate that is 20 times the reference clock. Data is transmitted LSB (TDx0) first.

**transmit data bus**

The transmit bus interface accepts 18-bit-wide, single-ended, TTL parallel data at the TDx[0:17] terminals. Data is valid on the rising edge of GTx\_CLK. The GTx\_CLK is used as the word clock. The data and clock signals must be properly aligned as shown in Figure 1. Detailed timing information can be found in the *TTL input electrical characteristics* table.

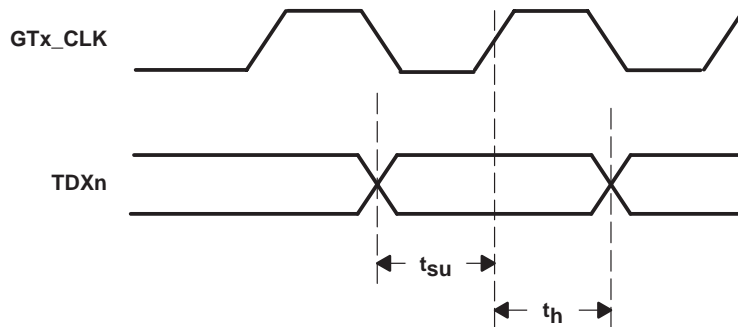

**Figure 1. Transmit Timing Waveform**

**transmission latency**

The data transmission latency of the transceiver is defined as the delay from the initial 18-bit word on the parallel transmit interface to the serial transmission of the start bit of the 20-bit frame containing the 18-bit word. The transmit latency is fixed once the link is established. However, due to silicon process variations and implementation variables, such as supply voltage and temperature, the exact delay varies slightly. Figure 2 illustrates the timing relationship between the transmit data bus, GTx\_CLK, and the serial transmit terminals.

# TLK4250 QUAD 1.0 to 2.5 Gbps TRANSCEIVER

SWRS025C – APRIL 2004 – REVISED JULY 2007

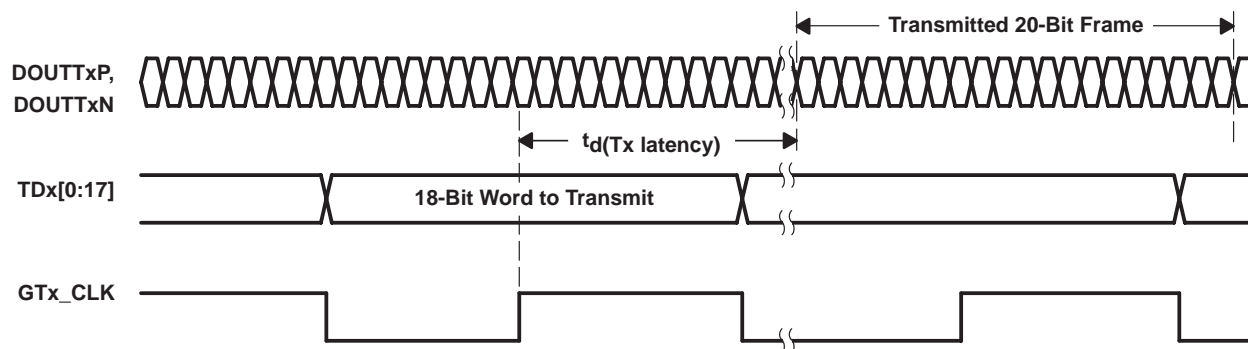

Figure 2. Transmitter Latency

## start/stop framing logic

All true serial interfaces require a method of encoding to ensure minimum transition density so that the receiving PLL has a minimal number of transitions in which to stay locked onto the data stream. The signal encoding also provides a mechanism for the receiver to identify the word boundary for correct deserialization. The TLK4250 transceiver wraps a start bit (1) and a stop bit (0) around the 18-bit data payload as shown in Figure 3. This is transparent to the user, as the transceiver internally adds the framing bits to the data such that the user reads and writes actual 18-bit data.

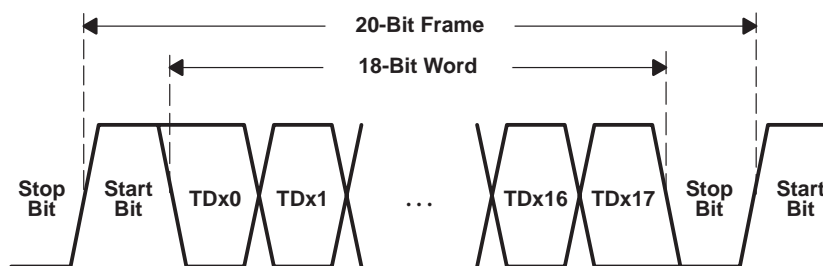

Figure 3. Serial Output Data Stream With Start and Stop Bit

## parallel-to-serial

The parallel-to-serial shift register takes in the 20-bit-wide frame multiplexed from the framing logic and converts it to a serial stream. The shift register is clocked on both the rising and falling edges of the internally generated bit clock, which is 10 times the GTx\_CLK input frequency. The LSB (TDx0) is first out after the start bit as shown in Figure 3.

## high-speed data output

The high-speed data output driver consists of a PECL-compatible differential pair that can be optimized for a particular transmission line impedance and length. The line can be directly coupled or ac coupled. See Figure 10 and Figure 11 for termination details. No external pullup or pulldown resistors are required.

The transceiver provides a selectable signal preemphasis option for driving lossy media. When signal preemphasis is enabled, the first bit of a run length of same-value bits (e.g., 111...) is driven to a larger output swing, which precompensates for signal inter-symbol interference (ISI) in lossy media, such as copper cables or printed circuit board traces.

**receive interface**

The receiver portion of the TLK4250 accepts 20-bit framed differential serial data. The interpolator and clock recovery circuit locks to the data stream and extracts the bit rate clock. This recovered clock retimes the input data stream. The serial data is then aligned to the 20-bit frame by finding the start and stop bits and the 18-bit data is output on a 18-bit wide parallel bus synchronized to the extracted receive clock (Rx\_CLK).

**receive data bus**

The receive bus interface drives 18-bit-wide, single-ended, TTL parallel data at the RDx[0:17] terminals. Data is valid on the rising edge of Rx\_CLK. The Rx\_CLK is used as the recovered word clock. The data and clock signals are aligned as shown in Figure 4. Detailed timing information can be found in the *TTL output switching characteristics* table.

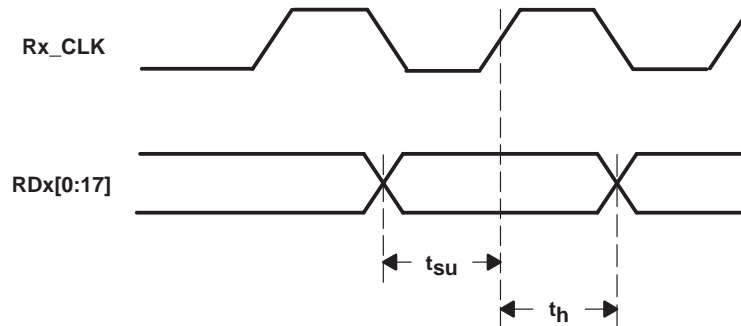

**Figure 4. Receive Timing Waveform**

**data reception latency**

The serial-to-parallel data receive latency is the time from when the start bit arrives at the receiver until the output of the aligned parallel word. The receive latency is fixed once the link is established. However, due to silicon process variations and implementation variables, such as supply voltage and temperature, the exact delay varies slightly. Figure 5 illustrates the timing relationship between the serial receive terminals, the recovered word clock (Rx\_CLK), and the receive data bus.

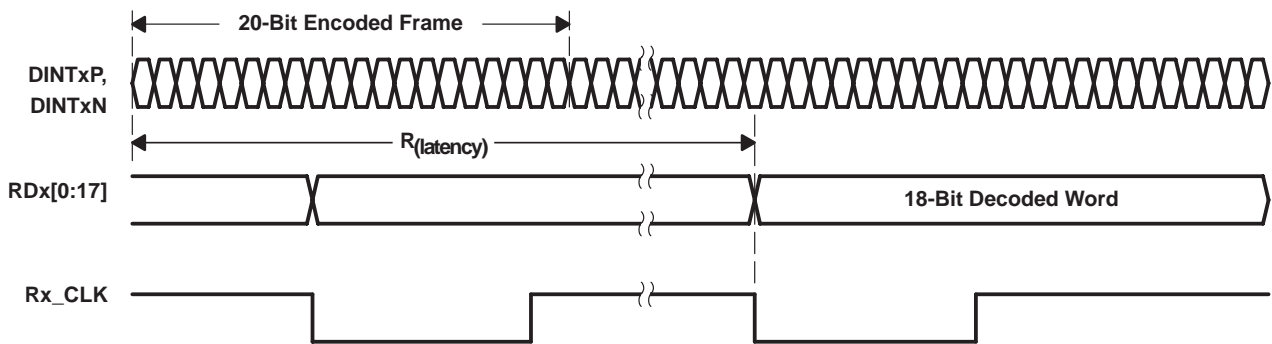

**Figure 5. Receiver Latency**

**serial-to-parallel**

Serial data is received on the DINRxP and DINRxN terminals. The interpolator and clock recovery circuit locks to the data stream if the clock to be recovered is within  $\pm 100$  PPM of the internally generated bit rate clock. The recovered clock retimes the input data stream. The serial data is then clocked into the serial-to-parallel shift registers.

# TLK4250

## QUAD 1.0 to 2.5 Gbps TRANSCEIVER

SWRS025C – APRIL 2004 – REVISED JULY 2007

---

### synchronization mode

The deserializer must synchronize to the serializer in order to receive valid data. Synchronization can be accomplished in one of two ways.

#### rapid synchronization

The serializer has the capability to send specific SYNC patterns consisting of 9 ones and 9 zeros, switching at the input clock rate. The transmission of SYNC patterns enables the deserializer to lock to the serializer signal within a deterministic time frame. The transmission of SYNC patterns is selected via the SYNC input on the serializer. On receiving a valid SYNC pulse (wider than 6 clock cycles), 1026 cycles of SYNC pattern are sent.

When the deserializer detects edge transitions at the serial input, it attempts to lock to the embedded clock information. The deserializer LOCKBx output remains inactive while its clock/data recovery (CDR) locks to the incoming data or SYNC patterns present on the serial input. When the deserializer locks to the serial data, the LOCKBx output goes active. When LOCKBx is active, the deserializer outputs represent incoming serial data. One approach is to tie the deserializer LOCKBx output directly to the SYNCx input of the transmitter. This ensures that enough SYNC patterns are sent to achieve deserializer lock.

#### random lock synchronization

The deserializer can attain lock to a data stream without requiring the serializer to send special SYNC patterns. This allows the transceiver to operate in open-loop applications. Equally important is the deserializer's ability to support hot insertion into a running backplane. In the open-loop or hot-insertion case, it is assumed the data stream is essentially random. Therefore, because lock time varies due to data stream characteristics, the exact lock time cannot be predicted. The primary constraint on the random lock time is the initial phase relation between the incoming data and the GTx\_CLK when the deserializer powers up.

The data contained in the data stream can also affect lock time. If a specific pattern is repetitive, the deserializer could enter false lock—falsely recognizing the data pattern as the start/stop bits. This is referred to as repetitive multitransition (RMT). This occurs when more than one low-high transition takes place per clock cycle over multiple clock cycles. In the worst case, the deserializer could become locked to the data pattern rather than the clock. Circuitry within the deserializer can detect that the possibility of false lock exists. On detection, the circuitry prevents the LOCKBx from becoming active until the potential false-lock pattern changes. Notice that the RMT pattern only affects the deserializer lock time, and once the deserializer is in lock, the RMT pattern does not affect the deserializer state as long as the same data boundary happens each cycle. The deserializer does not go into lock until it finds a unique data boundary that consists of four consecutive cycles of data boundary (start/stop bits) at the same position.

The deserializer stays in lock until it cannot detect the same data boundary (start/stop bits) for four consecutive cycles. Then the deserializer goes out of lock and hunts for the new data boundary (start/stop bits). In the event of loss of synchronization, the LOCKBx terminal output goes inactive and the outputs (including Rx\_CLK) enter a high-impedance state. The user's system must monitor the LOCKBx terminal in order to detect a loss of synchronization. On detection of loss of lock, sending SYNC patterns for resynchronization is desirable if reestablishing lock within a specific time is critical. However, the deserializer can lock to random data as previously noted. LOCKBx is held inactive for at least nine cycles after loss of lock is detected.

#### recommended power-up sequence

When powering up the device, it is recommended to first set the ENABLEx terminal low. Set the ENABLEx terminal to high once sufficient time has passed to allow the power supply to stabilize.

#### power-down mode

When the ENABLEx terminal is deasserted low, the transceiver goes into a power-down mode. In the power-down mode, the serial transmit terminals (DOUTrxP, DOUTrxN) and the receive data bus terminals (RDx[0:17]) go into a high-impedance state.

### **reference clock input**

The reference clock (GTx\_CLK) is an external input clock that synchronizes the transmitter interface. The reference clock is then multiplied in frequency 10 times to produce the internal serialization bit clock. The internal serialization bit clock is frequency locked to the reference clock and clocks out the serial transmit data on both its rising and falling edges, providing a serial data rate that is 20 times the reference clock.

The receiver tracking logic uses clock phases from the internal PLL as it aligns the recovered clock phase with the incoming serial data stream; therefore, the input reference clock (GTx\_CLK) is needed even if the transmit function of the TLK4250 is not being used. The receiver function has the ability to track an incoming serial data stream that is within  $\pm 200$  ppm of the data rate that is set by GTx\_CLK. This allows the use of clock sources with  $\pm 100$  ppm frequency tolerance.

### **operating frequency range**

The transceiver may operate at a serial data rate between 1.0 Gbps to 2.5 Gbps. GTx\_CLK must be within  $\pm 100$  PPM of the desired parallel data rate clock. Each individual channel may operate at a different rate.

### **testability**

The transceiver has a comprehensive suite of built-in self-tests. The loopback function provides for at-speed testing of the transmit/receive portions of the circuitry. The ENABLEx terminal allows for all circuitry to be disabled so that a quiescent current test can be performed.

### **loop-back testing**

The transceiver can provide a self-test function by enabling (LOOPENx) the internal loop-back path. Enabling this terminal causes serial transmitted data to be routed internally to the receiver. The parallel data output can be compared to the parallel input data for functional verification. (The external differential output is held in a high-impedance state during the loop-back testing.)

### **power-on reset**

On application of minimum valid power, the transceiver generates a power-on reset. During the power-on reset, the RDx terminals are 3-stated and Rx\_CLK is held low. The length of the power-on reset cycle depends on the GTx\_CLK frequency, but is less than 1 ms in duration.

# TLK4250

## QUAD 1.0 to 2.5 Gbps TRANSCEIVER

SWRS025C – APRIL 2004 – REVISED JULY 2007

### absolute maximum ratings over operating free-air temperature (unless otherwise noted)†

Supply voltage, $V_{DD}$ (see Note 1)	–0.3 V to 3 V
Voltage range at TDx, ENABLEx, GTx_CLK, LOOPENx, SYNCx, PREEMPHx	–0.3 V to 4 V
Voltage range at any other terminal except above	–0.3 V to $V_{DD} + 0.3$ V
Package power dissipation, $P_D$	See Dissipation Rating Table
Storage temperature, $T_{stg}$	–65°C to 150°C
Electrostatic discharge	HBM: 2 kV
Characterized free-air operating temperature range, $T_A$	–40°C to 85°C
Lead temperature 1,6 mm (1/16 inch) from case for 10 seconds	260°C

† Stresses beyond those listed under “absolute maximum ratings” may cause permanent damage to the device. These are stress ratings only, and functional operation of the device at these or any other conditions beyond those indicated under “recommended operating conditions” is not implied. Exposure to absolute-maximum-rated conditions for extended periods may affect device reliability.

NOTE 1: All voltage values, except differential I/O bus voltages, are with respect to network ground.

Air Flow	0 m/s	0.5 m/s	1 m/s	2.5 m/s
TJA (C/W)	18.4	16.92	15.95	14.7

### electrical characteristics over recommended operating conditions

PARAMETER	TEST CONDITION	MIN	TYP	MAX	UNIT
$V_{DD}$ Supply voltage		2.3	2.5	2.7	V
$T_A$ Operating free-air temperature		–40		85	°C
$I_{CC}$ Supply current	$V_{DD} = 2.5$ V, Rate = 1 Gbps, PRBS pattern		285		mA
	$V_{DD} = 2.5$ V, Rate = 2.5 Gbps, PRBS pattern		680		
$P_D$ Power dissipation	$V_{DD} = 2.5$ V, Rate = 1 Gbps, PRBS pattern		715		mW
	$V_{DD} = 2.5$ V, Rate = 2.5 Gbps, PRBS pattern		1700		
	$V_{DD} = 2.7$ V, Rate = 2.5 Gbps, worst case pattern†		2920		
Shutdown current	ENABLEx = 0, VDDA, $V_{DD}$ terminals, $V_{DD} =$ maximum		520		μA
PLL start-up lock time	$V_{DD}$ , VDDA = 2.3 V, EN ↑ to PLL acquire		0.1	0.4	ms
Data acquisition time			1024		bits

† Worst case pattern is a pattern that creates a maximum transition density on the serial transceiver.

### reference clock (GTx\_CLK) timing requirements over recommended operating conditions (unless otherwise noted)

PARAMETER	TEST CONDITIONS	MIN	TYP	MAX	UNIT
$R_{\omega}$ Frequency	Minimum data rate	TYP–0.01%	50	TYP+0.01%	MHz
	Maximum data rate	TYP–0.01%	125	TYP+0.01%	
Frequency tolerance		–100		100	ppm
Duty cycle		40%	50%	60%	
Jitter	Peak-to-peak			40	ps

TTL input electrical characteristics over recommended operating conditions (unless otherwise noted)

TTL Signals: TDx0 ... TDx17, GTx\_CLK, LOOPENx, SYNCx, PREEMPHx

PARAMETER	TEST CONDITIONS	MIN	TYP	MAX	UNIT
V <sub>IH</sub>	High-level input voltage	See Figure 6		3.6	V
V <sub>IL</sub>	Low-level input voltage	See Figure 6		0.8	V
I <sub>IH</sub>	High-level input current	V <sub>DD</sub> = Max, V <sub>IN</sub> = 2 V		40	μA
I <sub>IL</sub>	Low-level input current	V <sub>DD</sub> = Max, V <sub>IN</sub> = 0.4 V	-40		μA
C <sub>IN</sub>	Input capacitance	0.8 V to 2 V		4	pF
t <sub>r</sub>	GTx_CLK, TDx rise time	0.8 V to 2 V, C = 5 pF, see Figure 6	1		ns
t <sub>f</sub>	GTx_CLK, TDx fall time	2 V to 0.8 V, C = 5 pF, see Figure 6	1		ns
t <sub>su</sub>	TDx setup to ↑ GTx_CLK	See Figure 6	1.5		ns
t <sub>h</sub>	TDx hold to ↑ GTx_CLK	See Figure 6	0.4		ns

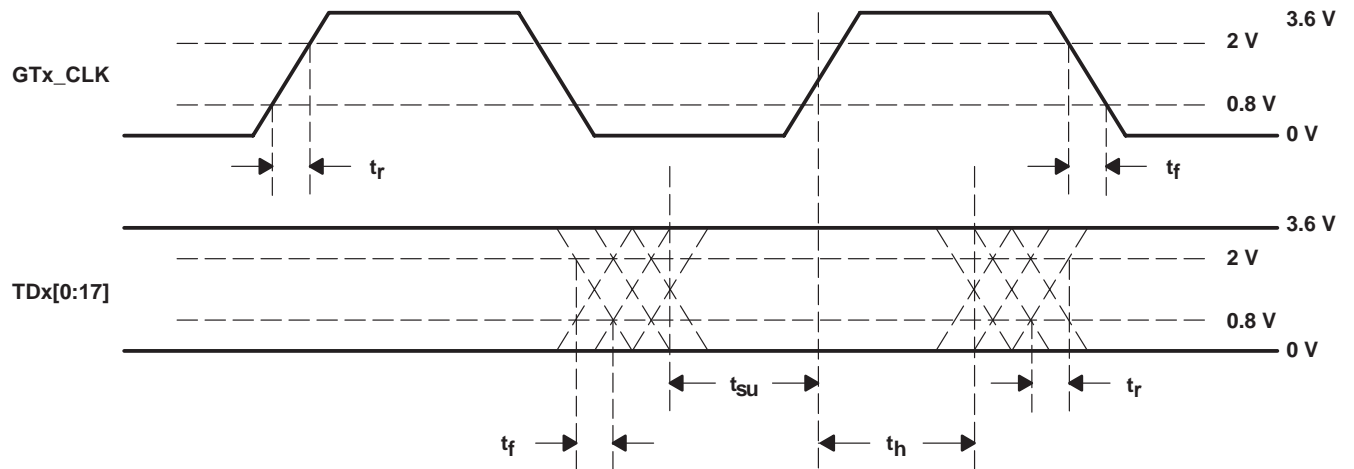

Figure 6. TTL Data Input Valid Levels for AC Measurements

# TLK4250 QUAD 1.0 to 2.5 Gbps TRANSCEIVER

SWRS025C – APRIL 2004 – REVISED JULY 2007

TTL output switching characteristics over recommended operating conditions (unless otherwise noted)

PARAMETER	TEST CONDITIONS	MIN	TYP	MAX	UNIT
$V_{OH}$ High-level output voltage	$I_{OH} = -1 \text{ mA}$ , $V_{DD} = \text{minimum}$	2.1	2.3		V
$V_{OL}$ Low-level output voltage	$I_{OL} = 1 \text{ mA}$ , $V_{DD} = \text{minimum}$	GND	0.25	0.5	V
$t_{r(\text{slew})}$ Magnitude of Rx_CLK, RDx slew rate (rising)	0.8 V to 2 V, $C = 5 \text{ pF}$ , see Figure 7	0.5			V/ns
$t_{f(\text{slew})}$ Magnitude of Rx_CLK, RDx slew rate (falling)	0.8 V to 2 V, $C = 5 \text{ pF}$ , see Figure 7	0.5			V/ns
$t_{su}$ RDx setup to $\uparrow$ Rx_CLK	50% voltage swing, $GTx\_CLK = 50 \text{ MHz}$ , see Figure 7	8			ns
	50% voltage swing, $GTx\_CLK = 125 \text{ MHz}$ , see Figure 7	3			ns
$t_h$ RDx hold to $\uparrow$ Rx_CLK	50% voltage swing, $GTx\_CLK = 50 \text{ MHz}$ , see Figure 7	8			ns
	50% voltage swing, $GTx\_CLK = 125 \text{ MHz}$ , see Figure 7	3			ns

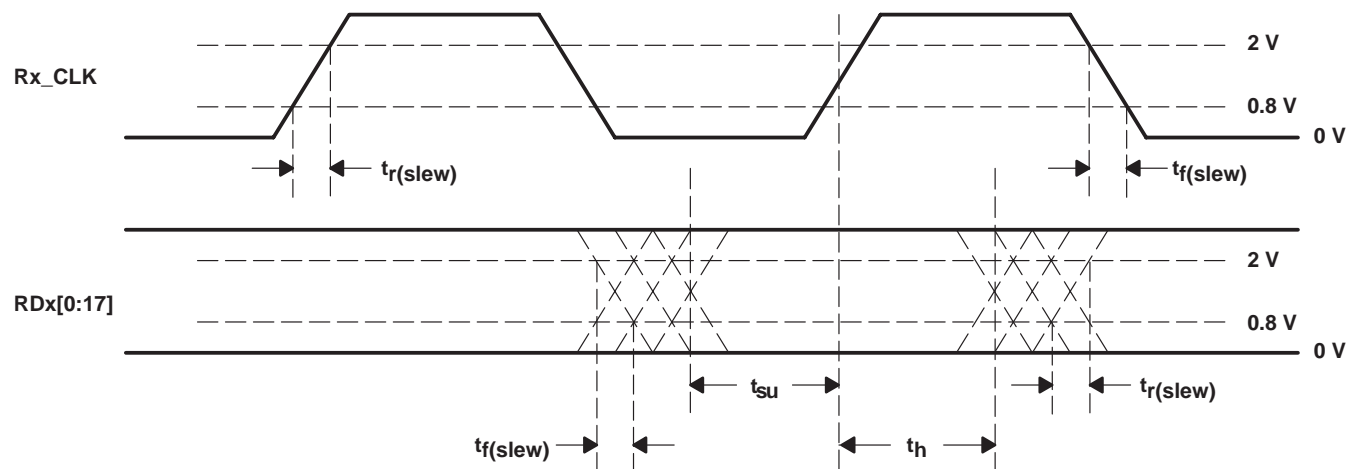
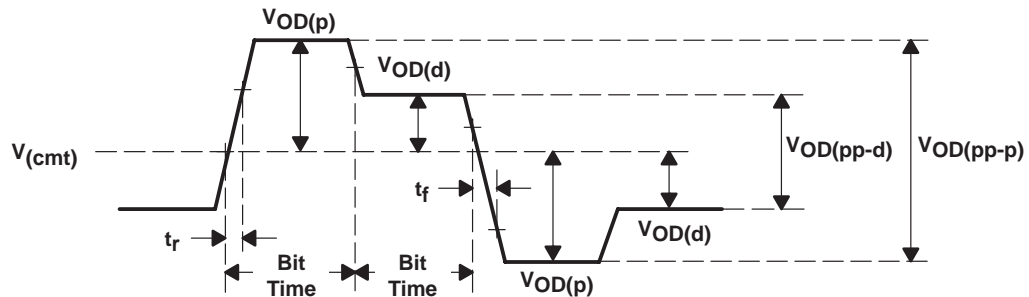

Figure 7. TTL Data Output Valid Levels for AC Measurements

**transmitter/receiver characteristics**

PARAMETER		TEST CONDITION	MIN	TYP	MAX	UNIT
V <sub>OD(p)</sub>	V <sub>OD(p)</sub> =  V <sub>TXP</sub> – V <sub>TXN</sub>  , Preemphasis VOD	DC-coupled. Preemphasis = high, see Figure 8	750	1000	1375	mV
		DC-coupled. Preemphasis = low, see Figure 8	650	950	1300	
V <sub>OD(pp-p)</sub>	Differential, peak-to-peak output voltage with preemphasis	DC-coupled. Preemphasis = high, see Figure 8	1500	2000	2750	mV
		DC-coupled. Preemphasis = low, see Figure 8	1000	1500	2600	
V <sub>OD(d)</sub>	V <sub>OD(d)</sub> =  V <sub>TXP</sub> – V <sub>TXN</sub>  , De-emphasis VOD	DC-coupled. See Figure 8	500	750	1100	mV
V <sub>OD(pp-d)</sub>	Differential, peak-to-peak output voltage with deemphasis	DC-coupled. See Figure 8	1000	1500	2200	mV
V <sub>(cmt)</sub>	Transmit termination voltage range, (V <sub>TXP</sub> + V <sub>TXN</sub> )/2		1000	1250	1400	mV
V <sub>ID</sub>	Receiver input voltage differential V <sub>ID</sub> =  R <sub>XP</sub> – R <sub>XN</sub>		200			mV
V <sub>cmt</sub>	Receiver common-mode voltage range, (V <sub>RXP</sub> + V <sub>RXN</sub> )/2		1000	V <sub>DD</sub> -350		mV
I <sub>in</sub>	Receiver input leakage		-10		10	μA
C <sub>in</sub>	Receiver input capacitance				2	pF
t <sub>r</sub> , t <sub>f</sub>	Differential output signal rise and fall time (20% to 80%)	R <sub>L</sub> = 50 Ω, C <sub>L</sub> = 5 pF, see Figure 9	100	150		ps
	Serial transmit data total jitter (peak-to-peak)	Differential output jitter, random + deterministic, 2 <sup>23</sup> – 1 PRBS pattern at 2.5 Gbps		0.15		UI
	Receive jitter tolerance	Total input jitter, PRBS pattern, permitted eye closure at zero crossing		0.5		UI
T <sub>latency</sub>	TX latency	At 1.0 Gbps				Bit times
		At 2.5 Gbps				
R <sub>latency</sub>	RX latency	At 1.0 Gbps				Bit times
		At 2.5 Gbps				



**Figure 8. Differential and Common-Mode Output Voltage Definitions**

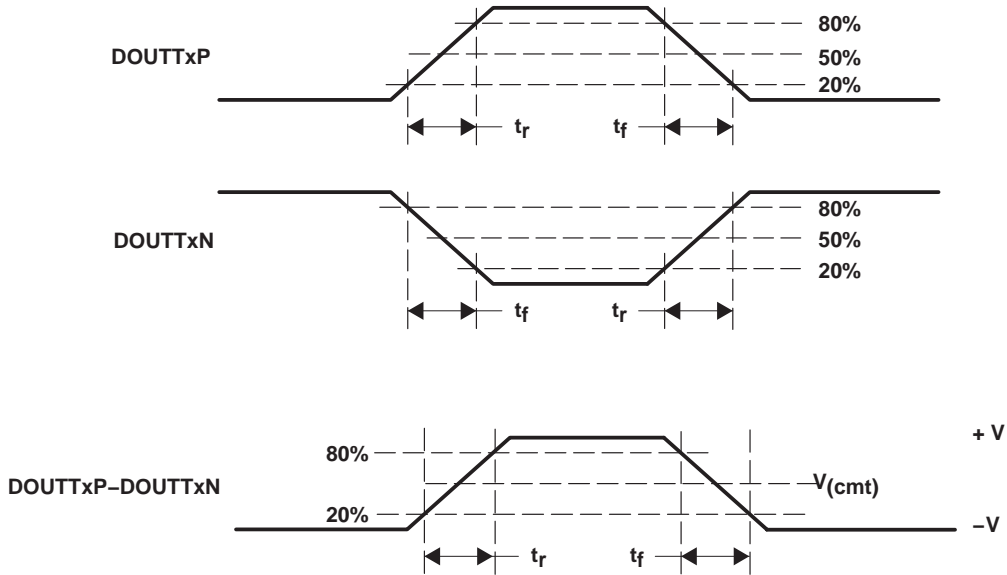

**Figure 9. Rise and Fall Time Definitions**

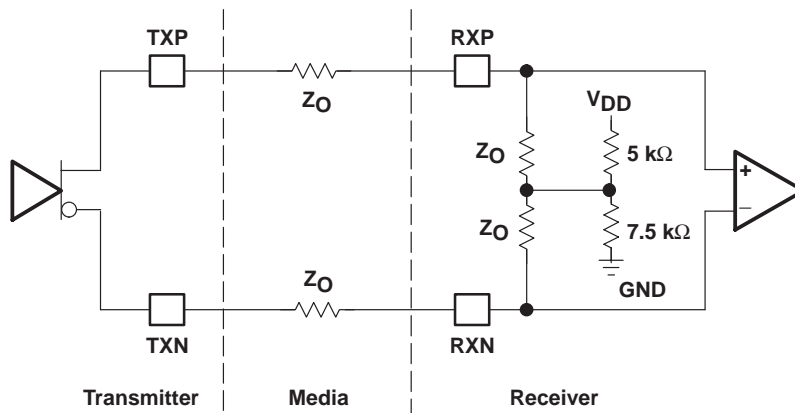

**Figure 10. High-Speed I/O Directly Coupled Mode**

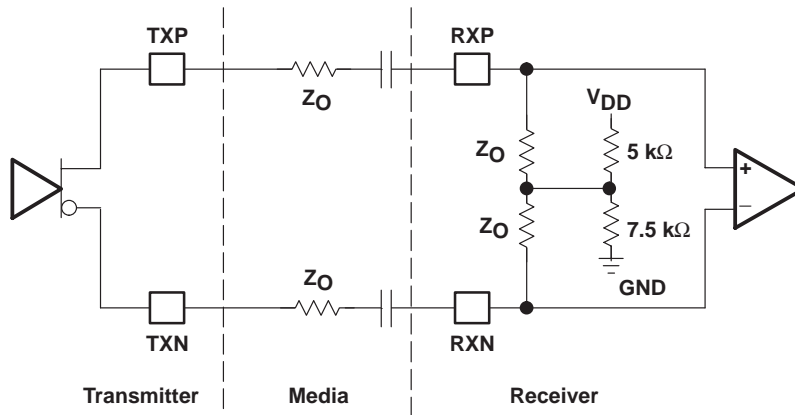

**Figure 11. High-Speed I/O AC-Coupled Mode**

AC-coupling is only recommended if the parallel TX data stream is encoded to achieve a dc-balanced data stream. Otherwise, the ac capacitors can induce common-mode voltage drift due to the dc-unbalanced data stream.

**PACKAGING INFORMATION**

Orderable Device	Status (1)	Package Type	Package Drawing	Pins	Package Qty	Eco Plan (2)	Lead/Ball Finish (6)	MSL Peak Temp (3)	Op Temp (°C)	Device Marking (4/5)	Samples
TLK4250GPV	PREVIEW	BGA	GPV	289		TBD	Call TI	Call TI	-40 to 85		
TLK4250IGPV	OBSOLETE	BGA	GPV	289		TBD	Call TI	Call TI		TLK4250I	
TLK4250IZPV	LIFEBUY	BGA	ZPV	289		TBD	Call TI	Call TI	-40 to 85	TLK4250I	

(1) The marketing status values are defined as follows:

**ACTIVE:** Product device recommended for new designs.

**LIFEBUY:** TI has announced that the device will be discontinued, and a lifetime-buy period is in effect.

**NRND:** Not recommended for new designs. Device is in production to support existing customers, but TI does not recommend using this part in a new design.

**PREVIEW:** Device has been announced but is not in production. Samples may or may not be available.

**OBSOLETE:** TI has discontinued the production of the device.

(2) Eco Plan - The planned eco-friendly classification: Pb-Free (RoHS), Pb-Free (RoHS Exempt), or Green (RoHS & no Sb/Br) - please check <http://www.ti.com/productcontent> for the latest availability information and additional product content details.

**TBD:** The Pb-Free/Green conversion plan has not been defined.

**Pb-Free (RoHS):** TI's terms "Lead-Free" or "Pb-Free" mean semiconductor products that are compatible with the current RoHS requirements for all 6 substances, including the requirement that lead not exceed 0.1% by weight in homogeneous materials. Where designed to be soldered at high temperatures, TI Pb-Free products are suitable for use in specified lead-free processes.

**Pb-Free (RoHS Exempt):** This component has a RoHS exemption for either 1) lead-based flip-chip solder bumps used between the die and package, or 2) lead-based die adhesive used between the die and leadframe. The component is otherwise considered Pb-Free (RoHS compatible) as defined above.

**Green (RoHS & no Sb/Br):** TI defines "Green" to mean Pb-Free (RoHS compatible), and free of Bromine (Br) and Antimony (Sb) based flame retardants (Br or Sb do not exceed 0.1% by weight in homogeneous material)

(3) MSL, Peak Temp. - The Moisture Sensitivity Level rating according to the JEDEC industry standard classifications, and peak solder temperature.

(4) There may be additional marking, which relates to the logo, the lot trace code information, or the environmental category on the device.

(5) Multiple Device Markings will be inside parentheses. Only one Device Marking contained in parentheses and separated by a "~" will appear on a device. If a line is indented then it is a continuation of the previous line and the two combined represent the entire Device Marking for that device.

(6) Lead/Ball Finish - Orderable Devices may have multiple material finish options. Finish options are separated by a vertical ruled line. Lead/Ball Finish values may wrap to two lines if the finish value exceeds the maximum column width.

**Important Information and Disclaimer:**The information provided on this page represents TI's knowledge and belief as of the date that it is provided. TI bases its knowledge and belief on information provided by third parties, and makes no representation or warranty as to the accuracy of such information. Efforts are underway to better integrate information from third parties. TI has taken and continues to take reasonable steps to provide representative and accurate information but may not have conducted destructive testing or chemical analysis on incoming materials and chemicals. TI and TI suppliers consider certain information to be proprietary, and thus CAS numbers and other limited information may not be available for release.

In no event shall TI's liability arising out of such information exceed the total purchase price of the TI part(s) at issue in this document sold by TI to Customer on an annual basis.

GPV (S-PBGA-N289)

PLASTIC BALL GRID ARRAY

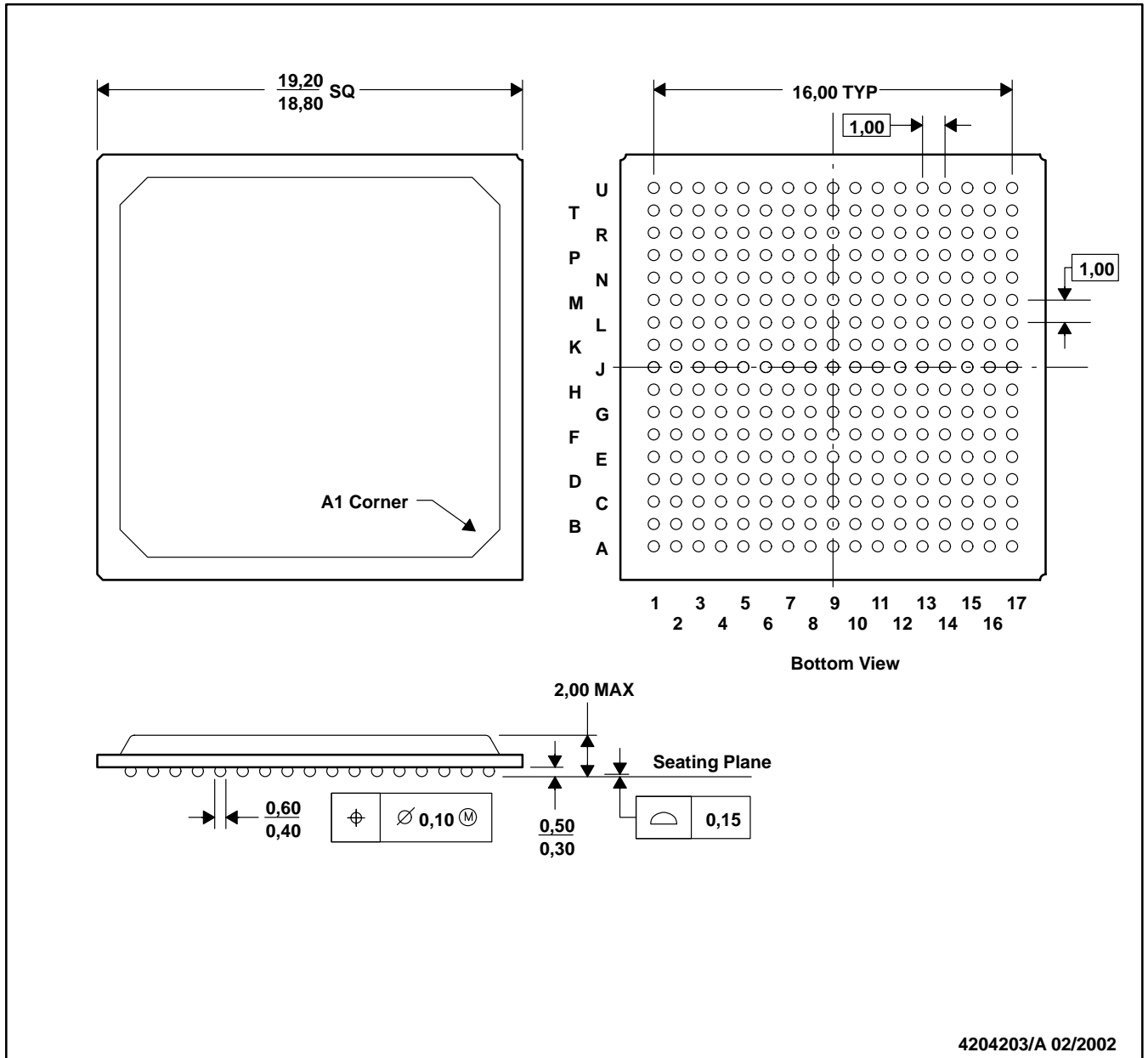

4204203/A 02/2002

- NOTES: A. All linear dimensions are in inches (millimeters).  
 B. This drawing is subject to change without notice.

ZPV (S-PBGA-N289)

PLASTIC BALL GRID ARRAY

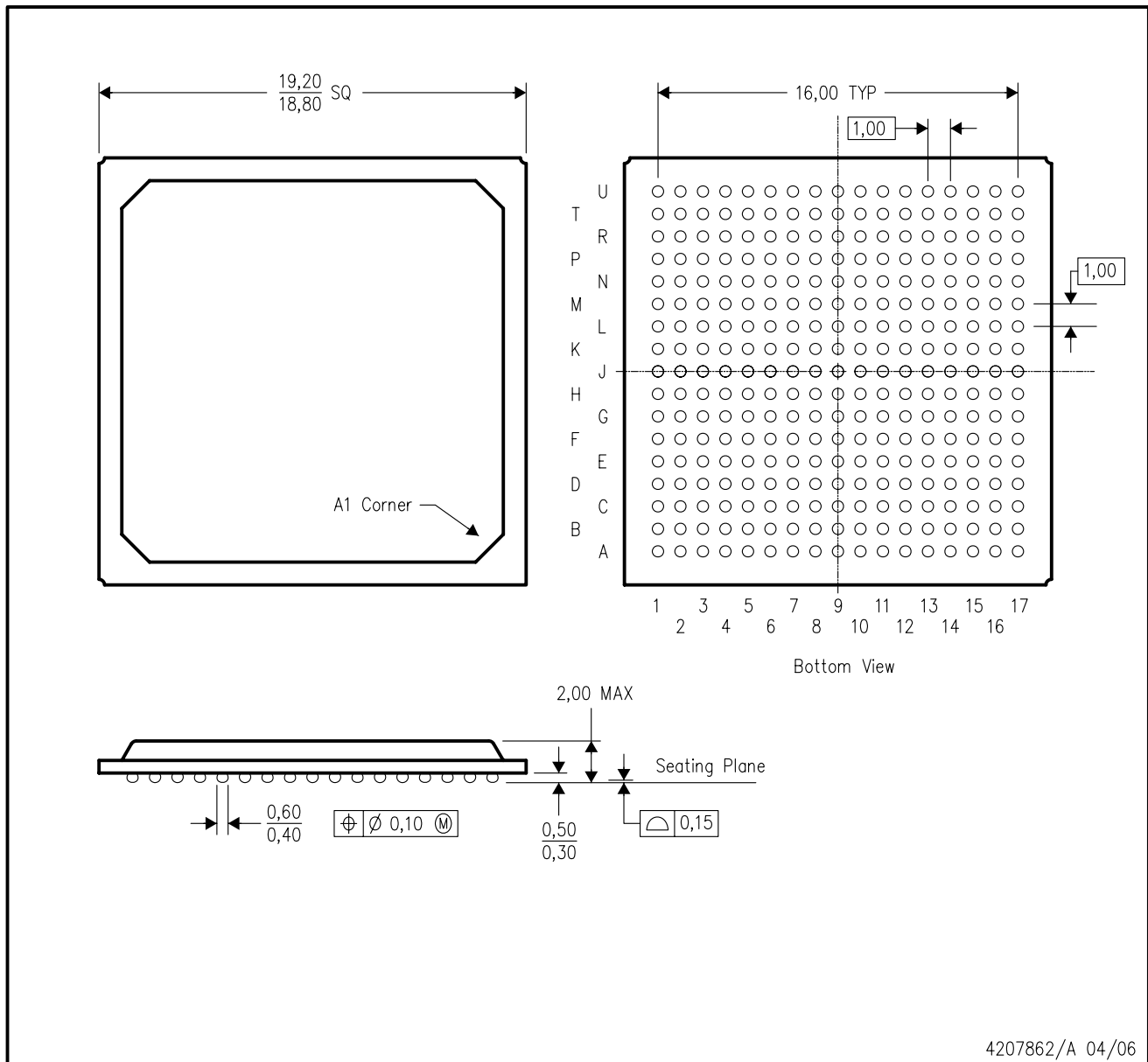

- NOTES:
- A. All linear dimensions are in millimeters.
  - B. This drawing is subject to change without notice.
  - C. This is a lead-free solder ball design.

## IMPORTANT NOTICE

Texas Instruments Incorporated and its subsidiaries (TI) reserve the right to make corrections, enhancements, improvements and other changes to its semiconductor products and services per JESD46, latest issue, and to discontinue any product or service per JESD48, latest issue. Buyers should obtain the latest relevant information before placing orders and should verify that such information is current and complete. All semiconductor products (also referred to herein as "components") are sold subject to TI's terms and conditions of sale supplied at the time of order acknowledgment.

TI warrants performance of its components to the specifications applicable at the time of sale, in accordance with the warranty in TI's terms and conditions of sale of semiconductor products. Testing and other quality control techniques are used to the extent TI deems necessary to support this warranty. Except where mandated by applicable law, testing of all parameters of each component is not necessarily performed.

TI assumes no liability for applications assistance or the design of Buyers' products. Buyers are responsible for their products and applications using TI components. To minimize the risks associated with Buyers' products and applications, Buyers should provide adequate design and operating safeguards.

TI does not warrant or represent that any license, either express or implied, is granted under any patent right, copyright, mask work right, or other intellectual property right relating to any combination, machine, or process in which TI components or services are used. Information published by TI regarding third-party products or services does not constitute a license to use such products or services or a warranty or endorsement thereof. Use of such information may require a license from a third party under the patents or other intellectual property of the third party, or a license from TI under the patents or other intellectual property of TI.

Reproduction of significant portions of TI information in TI data books or data sheets is permissible only if reproduction is without alteration and is accompanied by all associated warranties, conditions, limitations, and notices. TI is not responsible or liable for such altered documentation. Information of third parties may be subject to additional restrictions.

Resale of TI components or services with statements different from or beyond the parameters stated by TI for that component or service voids all express and any implied warranties for the associated TI component or service and is an unfair and deceptive business practice. TI is not responsible or liable for any such statements.

Buyer acknowledges and agrees that it is solely responsible for compliance with all legal, regulatory and safety-related requirements concerning its products, and any use of TI components in its applications, notwithstanding any applications-related information or support that may be provided by TI. Buyer represents and agrees that it has all the necessary expertise to create and implement safeguards which anticipate dangerous consequences of failures, monitor failures and their consequences, lessen the likelihood of failures that might cause harm and take appropriate remedial actions. Buyer will fully indemnify TI and its representatives against any damages arising out of the use of any TI components in safety-critical applications.

In some cases, TI components may be promoted specifically to facilitate safety-related applications. With such components, TI's goal is to help enable customers to design and create their own end-product solutions that meet applicable functional safety standards and requirements. Nonetheless, such components are subject to these terms.

No TI components are authorized for use in FDA Class III (or similar life-critical medical equipment) unless authorized officers of the parties have executed a special agreement specifically governing such use.

Only those TI components which TI has specifically designated as military grade or "enhanced plastic" are designed and intended for use in military/aerospace applications or environments. Buyer acknowledges and agrees that any military or aerospace use of TI components which have **not** been so designated is solely at the Buyer's risk, and that Buyer is solely responsible for compliance with all legal and regulatory requirements in connection with such use.

TI has specifically designated certain components as meeting ISO/TS16949 requirements, mainly for automotive use. In any case of use of non-designated products, TI will not be responsible for any failure to meet ISO/TS16949.

### Products

Audio	<a href="http://www.ti.com/audio">www.ti.com/audio</a>
Amplifiers	<a href="http://amplifier.ti.com">amplifier.ti.com</a>
Data Converters	<a href="http://dataconverter.ti.com">dataconverter.ti.com</a>
DLP® Products	<a href="http://www.dlp.com">www.dlp.com</a>
DSP	<a href="http://dsp.ti.com">dsp.ti.com</a>
Clocks and Timers	<a href="http://www.ti.com/clocks">www.ti.com/clocks</a>
Interface	<a href="http://interface.ti.com">interface.ti.com</a>
Logic	<a href="http://logic.ti.com">logic.ti.com</a>
Power Mgmt	<a href="http://power.ti.com">power.ti.com</a>
Microcontrollers	<a href="http://microcontroller.ti.com">microcontroller.ti.com</a>
RFID	<a href="http://www.ti-rfid.com">www.ti-rfid.com</a>
OMAP Applications Processors	<a href="http://www.ti.com/omap">www.ti.com/omap</a>
Wireless Connectivity	<a href="http://www.ti.com/wirelessconnectivity">www.ti.com/wirelessconnectivity</a>

### Applications

Automotive and Transportation	<a href="http://www.ti.com/automotive">www.ti.com/automotive</a>
Communications and Telecom	<a href="http://www.ti.com/communications">www.ti.com/communications</a>
Computers and Peripherals	<a href="http://www.ti.com/computers">www.ti.com/computers</a>
Consumer Electronics	<a href="http://www.ti.com/consumer-apps">www.ti.com/consumer-apps</a>
Energy and Lighting	<a href="http://www.ti.com/energy">www.ti.com/energy</a>
Industrial	<a href="http://www.ti.com/industrial">www.ti.com/industrial</a>
Medical	<a href="http://www.ti.com/medical">www.ti.com/medical</a>
Security	<a href="http://www.ti.com/security">www.ti.com/security</a>
Space, Avionics and Defense	<a href="http://www.ti.com/space-avionics-defense">www.ti.com/space-avionics-defense</a>
Video and Imaging	<a href="http://www.ti.com/video">www.ti.com/video</a>

### TI E2E Community

[e2e.ti.com](http://e2e.ti.com)